

NOTES:

1. LOCKS: FLUSH MOUNTED, SINGLE POINT, KEY LOCKING, ROTARY ACTION, COMPLETE STAINLESS STEEL, PADDLE TYPE LOCKS (AUTOMOTIVE QUALITY, DOUBLE BITTED LOCK CYLINDER) (ALL LOCKS KEYPED ALIKE) (ALL LOCKS RIVETED TO DOORS)
2. DOOR SEAL: "DUAL-PRO" AUTOMOTIVE QUALITY BUBBLE TYPE DOOR SEAL WITH HIGH BOND PSA HEAT SEALED BACKING AND DIE FORMED V-CHANNELS THAT MESH WITH VERTICAL AND HORIZONTAL DOOR FRAME BAFFLES TO CREATE A MECHANICAL SEAL. (67 FT. "DUAL-PRO" SEAL - NOT INSTALLED)
3. NITROGEN GAS PROP DOOR HOLDERS ON ALL VERTICAL DOORS - ROADSIDE AND CURBSIDE
4. BODY PAINTED IN PRIMER ONLY - INSIDE AND OUTSIDE
5. COMPLETE UNDERSTRUCTURE UNDERCOATED

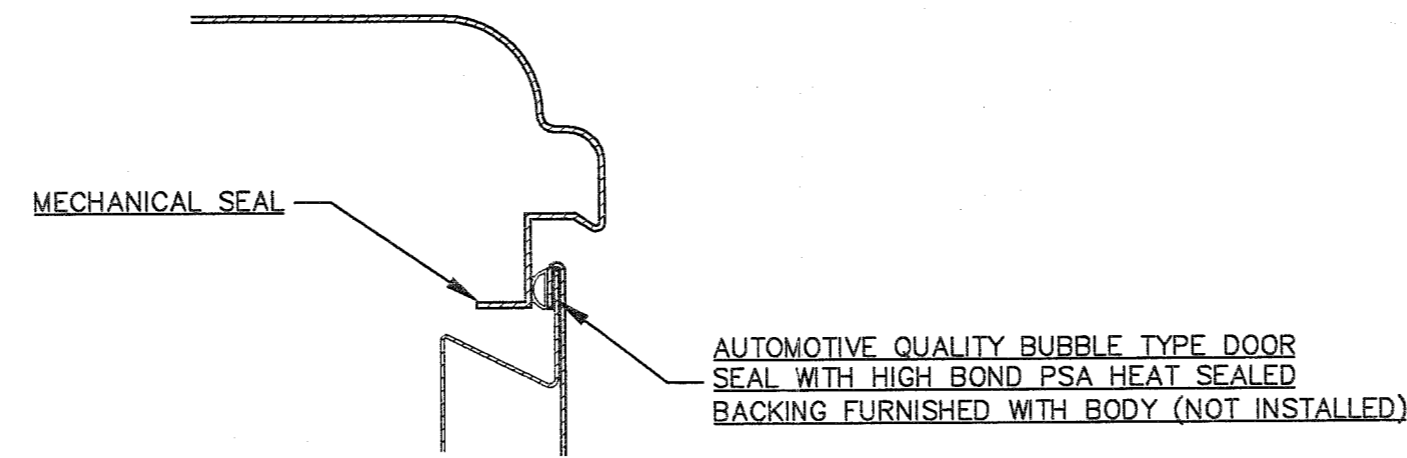

SECTION "A"-"A"

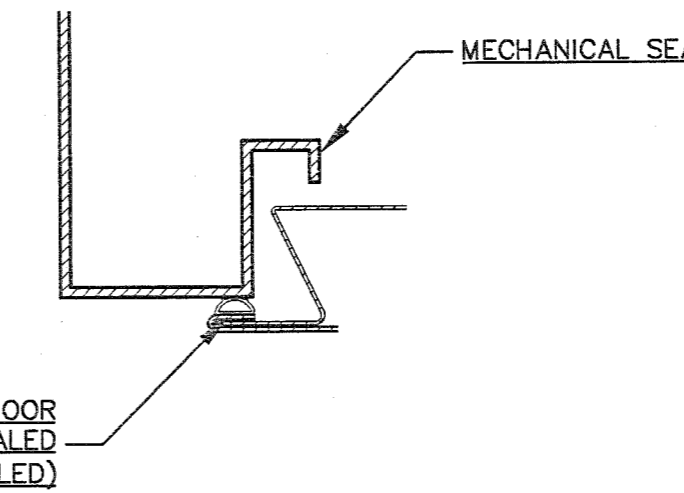

SECTION "B"-"B"

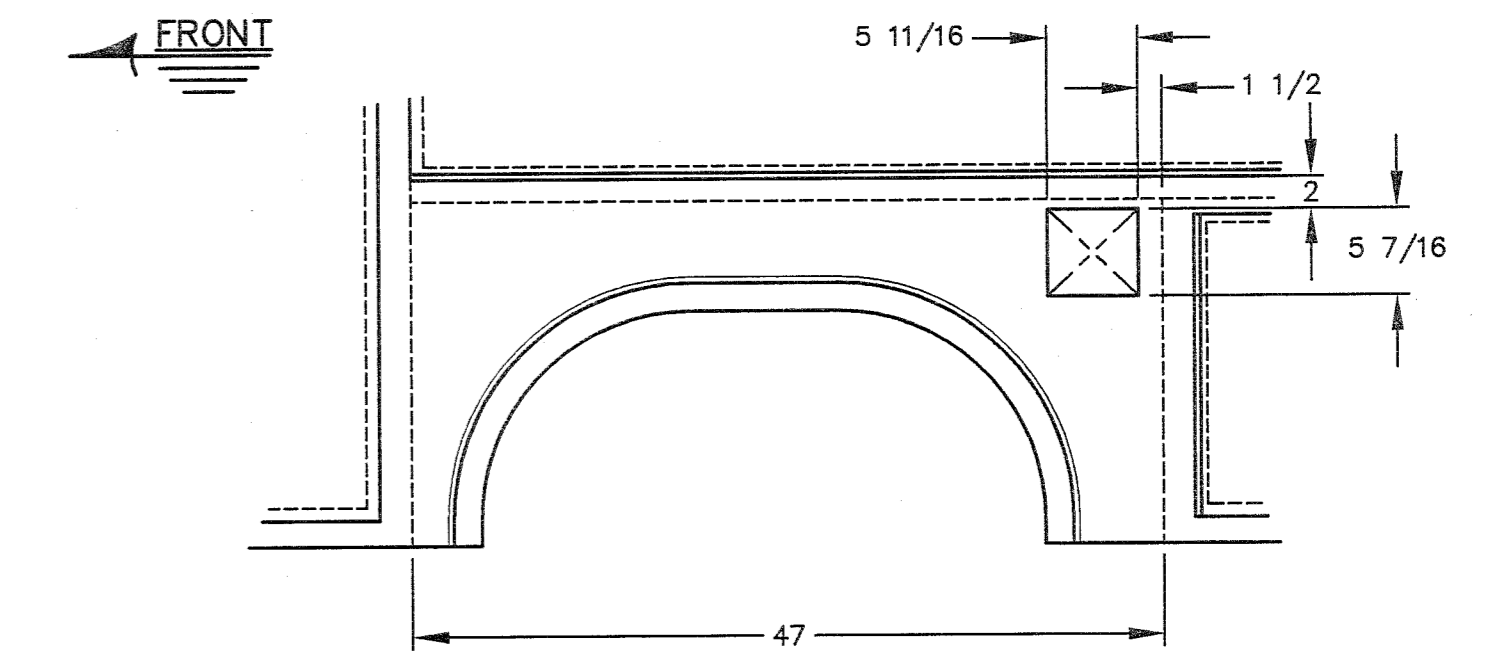

DETAIL "C"
("ALUMA-FILL" FUEL FILL CUT-OUT)
(1) REQUIRED - ROADSIDE

These boxes need to be resized

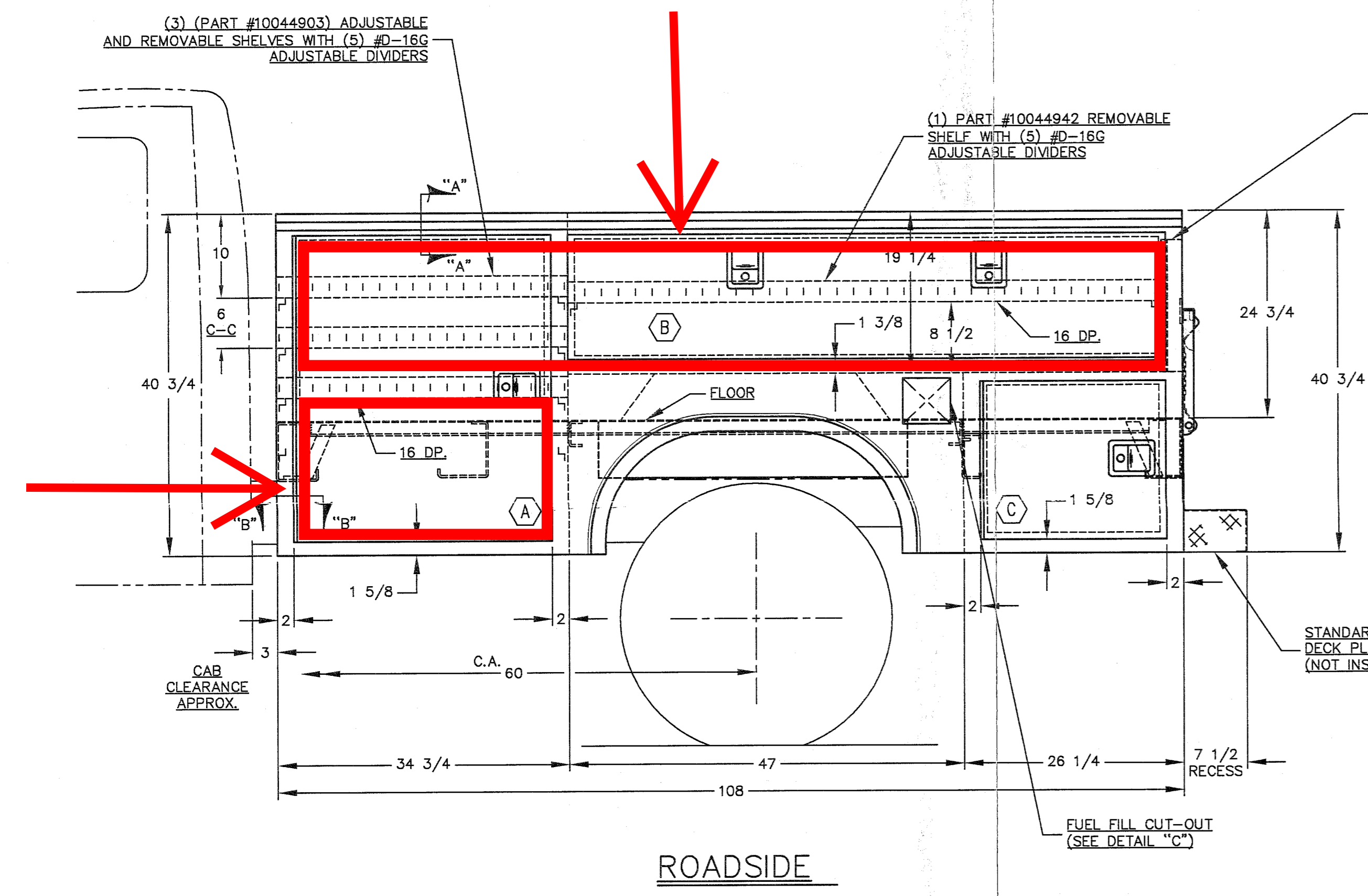

ROADSIDE

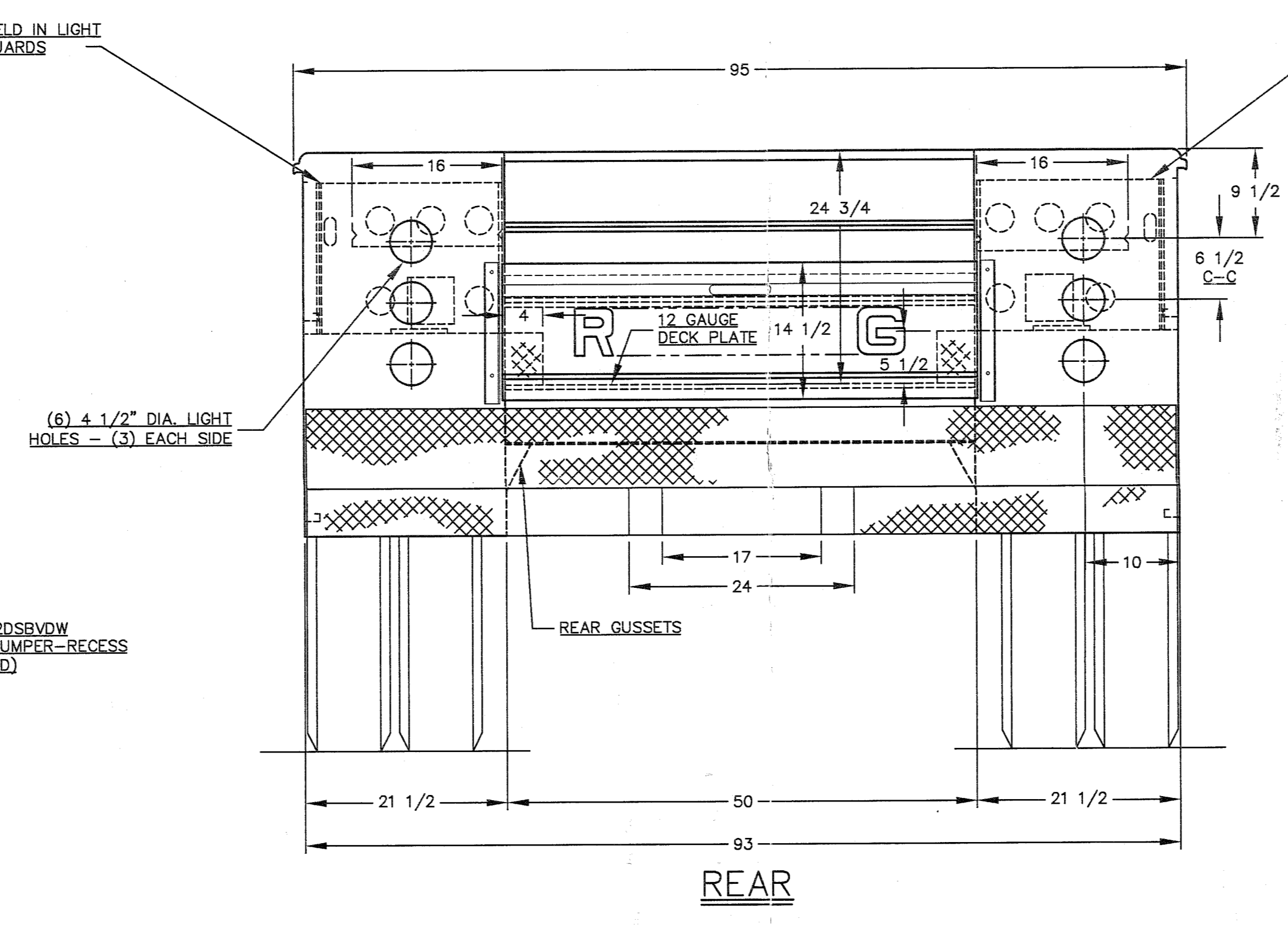

REAR

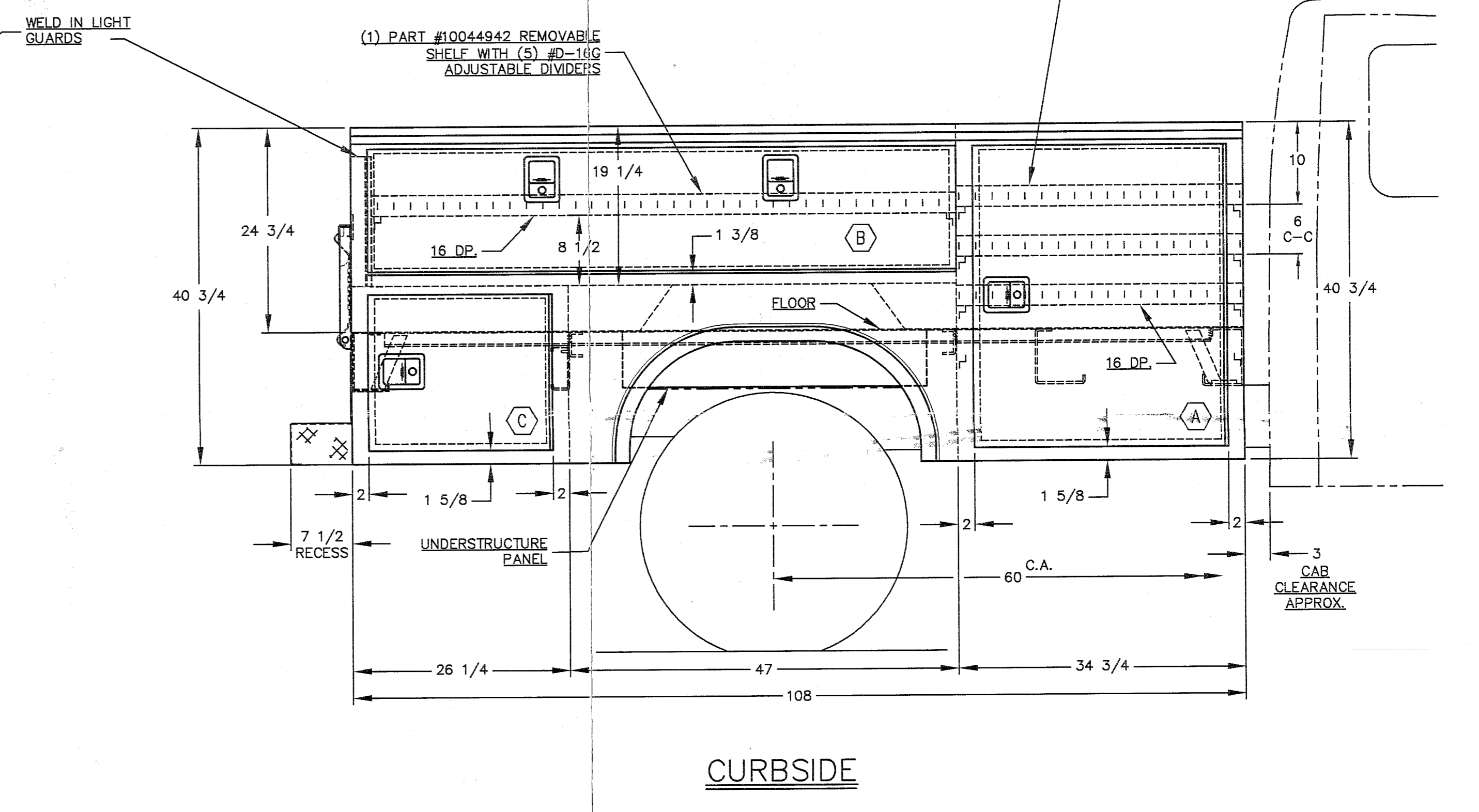

CURBSIDE

DOOR	CLEAR OPENING	DOOR FRAME SIZE	DOOR SIZE
A	29 1/4 x 35 1/4	30 3/4 x 36	32 1/4 x 37 3/8 H.
B	69 3/4 x 14	71 1/4 x 14 3/4	72 3/8 H. x 16 1/4 H.
C	20 3/4 x 17 5/8	22 1/4 x 18 3/8	23 3/4 x 19 3/4 H.
BODY TOLERANCE: ± 3/8"		DOOR TOLERANCE: ± 1/4"	

Note: Reading Bodies are not designed to be a torsional structure to resist twisting loads induced by Aerial Devices, derricks or other attachments. It is the responsibility of the final installer of the Derrick, Aerial Device or other Attachment, in conjunction with the manufacturer of the device, to provide an appropriately sized subframe (or torsion isolation mounting structure) to prevent excessive body twisting.

Note: Any bolted on items, to Reading Bodies, such as ladder racks or top boxes must have both surfaces top Coated prior to bolting and Bolts must be on 8" to 10" centers and as close to outer edges as possible. Urethane sealer must be used to seal all exposed edges to prevent entry of water between mating surfaces.

Body twisting must not exceed 3/8" in 9 Ft. or 1/2" in 14 Ft.

Bodies that are not mounted in compliance with these mounting recommendations will not be warranted against stress fracturing by: READING BODY WORKS

NOTE:
BODY TO BE MOUNTED ON A FORD CHASSIS MODEL F-450 WITH A 60" C.A. AND STANDARD DUAL REAR TIRES

REVISIONS	Any reproduction or distribution of this work without the express written consent of Reading Truck Body, Inc. is a violation of the Federal Copyright Act, Title 17, U.S. Code Section 101 et. seq., and other applicable laws. Criminal prosecution and civil damages will be pursued upon the occurrence of any infringement.			
<p>READING TRUCK BODY, INC. HANCOCK BLVD. & GERRY ST. READING, PA.</p> <p>STANDARD READING MODEL U-108B D.W. CLASSIC II SERVICE BODY</p> <p>FOUTS BROS., INC. FOR CITY OF ROME</p>				
DATE 4/18/05	DRAWN BY T.D.G.	CHECKED BY JBY	DRAWING NO. 050427	
SCALE 1" = 1'-0"	TRACED BY	APPROVED BY		

050427

IF IN DOUBT- ASK